

AT-610P User Manual

ISSUE 1.0

2009-9-11

1st、	AT-610P's Network Features	4
1、	The View	4
2、	Interfaces	4
3、	Electricity characteristic	4
4、	Software.....	4
5、	Network:	5
6、	Management and Maintenance	5
7、	Protocol	6
8、	Compliant Standard.....	6
9、	Operating Requirement	6
10、	Packing List	6
11、	Installation	7
2nd、	Feet installation instruction	7
3rd、	Keypad of IP Phone:	10
4th、	Basic functions and operations	12
1、	Answer the calls	12
2、	Make Call	13
3、	Hang up the phone	13
4、	Call Transfer.....	13
5、	3-way conference call	14
6、	Call Hold.....	14
7、	Call History.....	14
8、	Call pickup.....	15
9、	Join call.....	15
10、	Redial/Unredial	15
11、	vport	16
12、	Click to dial	17
13、	Preload Password.....	17
14、	Check the Phone's IP.....	17
5th、	Web settings.....	17
1、	Current state	18
2、	Network	18
3、	VoIP.....	20
4、	Advance.....	23
4.1.	SIP.....	23
4.2.	Digital Map	26
4.3.	Stun	27
4.4.	Call Service	28
4.5.	Audio Settings	29

5、	Dial Peer.....	30
6、	Config Manage.....	33
7、	Update.....	33
7.1.	Web Update.....	33
7.2.	FTP/TFTP Update.....	34
7.3.	Auto Provisioning.....	35
8、	System Manage.....	36
8.1.	Account Manage.....	36
8.2.	Phone Book.....	37
8.3.	Syslog Config.....	37
8.4.	Time Set.....	39
8.5.	Call Log.....	40
8.6.	Logout.....	40
8.7.	Reboot.....	40

1st、 AT-610P's Network Features

1、 The View



2、 Interfaces

- Power: Output Power: 12VDC, 500mA.
- WAN: RJ45 port.
- LAN: RJ45 port.

3、 Electricity characteristic

- Specialty of electric: output 12V 500mA DC
- The network connects: 2 RJ45 connect, a WAN, a LAN
- Headset jack : RJ9 jack * 2
- Support PoE

4、 Software

- Sip 2.0 (RFC3261)
- Two lines SIP, support IAX2

- STUN
- Jitter Buffer(200ms),VAD,CNG
- G.711A/u、G.722、G.723、G.729 Codec
- G.168 compliant 96ms echo cancellation
- Support SIP domain, SIP authentication(none, basic,MD5) .
- Support inbound audio, RFC2833 and SIP info , DTMF transmission way
- SIP Call Forward、Call transfer、Call hold、Call waiting, 3-way talking、Pickup、Join call、Redial、Unredial、Call Park、Vport、Click to dial
- Dial without register
- Support Hotline、DND(Do Not Disturb)、Blacklists、Call Limitation、DND、Incoming list
- Dial-peer calling rule, IP to IP call
- SIP server conference
- Phone book with 500 records, 100 answered call、missed call for each
- Support HTTP、FTP TFTP updating the configuration and firmware
- Syslog
- Answering machine
- Support SNMP client
- Telnet, WEB visit terminal
- Support different level user management

5、 Network:

- WAN/LAN: Support bridge or route mode
- Support base of NAT and NAPT
- Support PPPoE, (ADSL, cable modem use for internet connecting)
- WAN support Primary and Alter function
- WAN support DHCP Client
- Qos support Diffserv
- Support Network command tool: include ping, trace route, telnet

6、 Management and Maintenance

- Support safe mode and firmware updating under safe mode
- Support different level user management
- Configuration via web , keyboard and command
- Firmware and configuration updating via HTTP , FTP and TFTP
- Support system log and calling record
- configuration auto provision

7、 Protocol

- IEEE 802.3 /802.3 u 10 Base T / 100Base TX
- PPPoE: PPP over Ethernet
- SIP RFC3261, RFC 2543
- TCP/IP: Transfer Control Protocol/Internet Protocol
- RTP: Real-time Transport Protocol
- RTCP: RTP Control Protocol
- VAD/CNG
- Telnet: remote host access protocol
- DNS: Domain Name Server
- TFTP: Trivial File Transfer Protocol
- HTTP: Hypertext Transfer Protocol
- FTP: File Transfer Protocol

8、 Compliant Standard

- CE: EN55024,EN55022
- FCC part15
- Comply with ROHS in EU
- Comply with ROHS in China



Explanation:

The letter "e" is the first letter of "environment: and "electronic". The rim is a round with two arrow, stands for recycle. The number 20 stands for the years of environment protection. Please note the years of environment protection is not discarding year nor usage life.

9、 Operating Requirement

- Operation temperature: 0 to 40° C (32° to 104° F)
- Storage temperature: -30° to 65° C (-22° to 149° F)
- Humidity: 10 to 90% no dew

10、 Packing List

- AT-610P IP phone
- Power adaptor (output 12v ,500mA)
- Manual CD

11、 Installation

Use Ethernet cable to connect AT-610P's LAN port and your computer. Set computer's IP to the network 192.168.10.x or using dynamic obtain IP. Open web browser and key in 192.168.10.1. Then user will see the logon page of AT-610P, the default username and password is admin/admin for administrator and guest/guest for guest.

Set up page for VoIP user only:

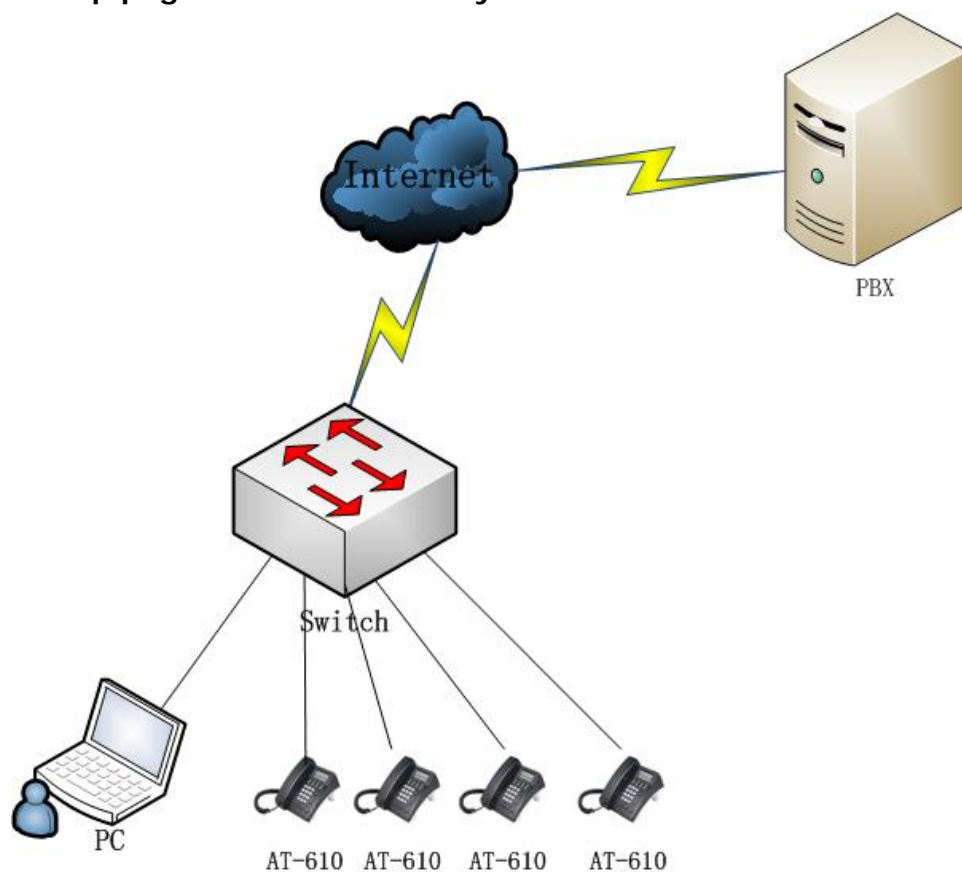

2nd、 Feet installation instruction

1、 Desktop position:

- A、 Put the bottom side of the IP phone upside and press the plate with letter “PUSH” into the slot, please refer the picture as below:

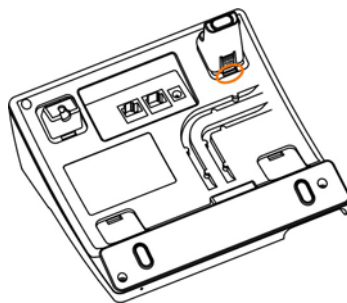

B、 Press the other plate into the slot in accordance with the direction of the arrow

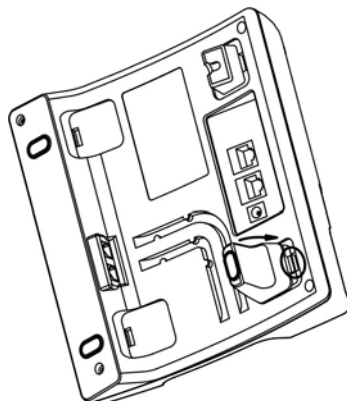

C、 Repeat A and B. It is the right picture of putting on desk after fixing the two feet below:

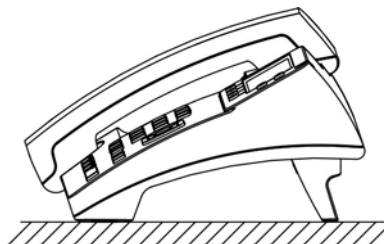

D、 Disassemble the feet:

Press the plate with word “PUSH” and pull the feet with the direction of arrow. When the plate is pull out of the slot (there will be a sound of “pa”) you can take off the feet

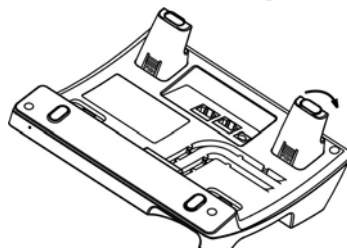

2、 On wall postion

A、 Put the bottom side of the IP phone upside and push the plate with letter “PUSH” into the slot, please refer the picture as below:

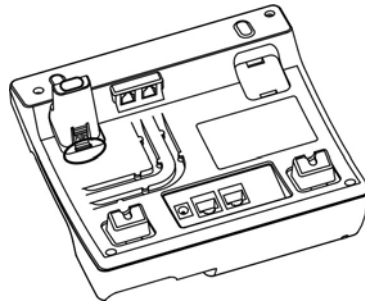

B、 Push the other plate into the slot in accordance with the direction of the arrow

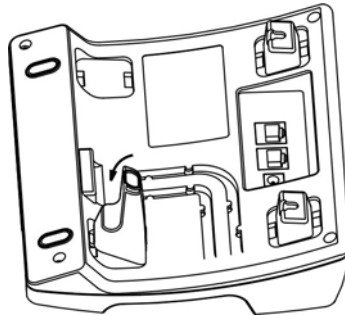

C、 Repeat A and B. It is the picture of wall mounting after fixing the two feet below:

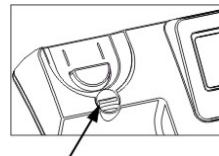
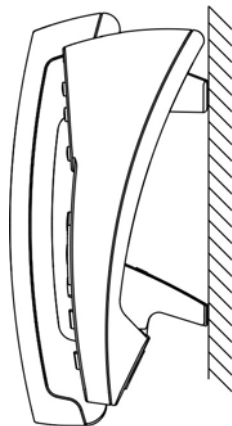

Attention: Please rotate the hook to the position as in picture with a coin or other tools

D、 Disassemble the feet way:

Press the plate with word “PUSH” and pull the feet with the direction of arrow. When the plate is pull out of the slot (there will be a sound of “pa”) you can take off the feet

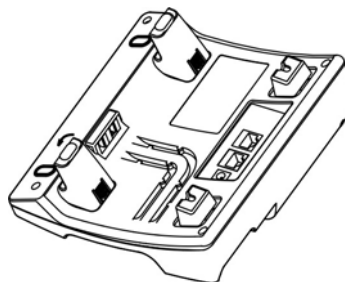

3rd、 Keypad of IP Phone:

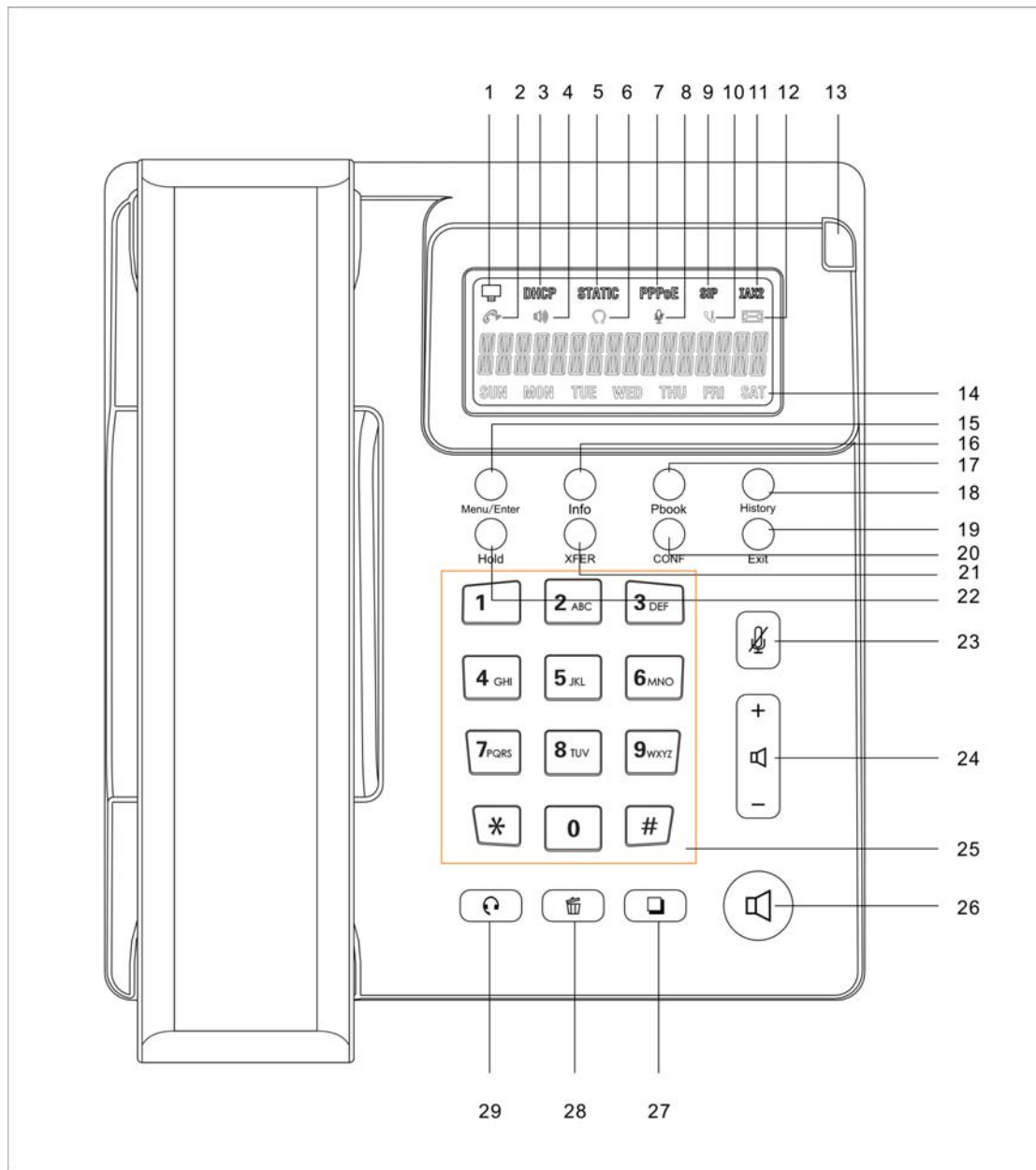

Sketch Map of Phone

Description:

Number	Function description
1	Network status indicator A、 when the network is OK , it's on B、 when the network can not connect , it blinks
3、 5、 7	Network mode indicator A、 Number 3 stands for DHCP , when the IP phone get IP address in DHCP Mode . the indicator is on , or else it blinks B、 Number 5 stands for Static , when the IP phone get IP address in Static mode . the indicator is on , or else it blinks

	C、 Number 7 stands for PPPoE, when the IP phone get IP address in PPPoE mode . the indicator is on , or else it blinks
2、 4、 6	Answering mode indicator , A、 Number 2 stands for answering call with handset B、 Number 4 stands for answering call in hand-free mode C、 Number 6 stands for answering call with headset
8	Mute indicator , when the phone is muted , this indicator is on , when the muted mode is canceled the indicator will be off
9、 11	Protocol indicator A、 Number 9 stands for SIP ➤ When you enable register and successfully register to SIP server , this indicator is on ➤ when you enable register but do not successfully register to server , this indicator blinks ➤ when you disable register , this indicator is off B、 Number 11 stands for IAX protocol ➤ When you enable register and successfully register to IAX server , this indicator is on ➤ when you enable register but do not successfully register to server , this indicator blinks ➤ when you disable register , this indicator is off
10	Missed call indicator , when there is the missed call , this indicator will be on . After you checked all the missed calls , this indicator will turn off
12	Voicemail indicator , when there is new voice mail , this indicator will be on , after you checked all the voicemail , this indicator will turn off
13	incoming call indicator A、 when the phone is in standby without incoming call , the indicator is off B、 when the Ethernet connection is off , the indicator is on C、 when there is the incoming call , indicator blinks D、 when there is a new voicemail , the indicator blinks
14	Monday to Sunday indicator , the correct day will be on while others will be off
15	This is the multi function key A、 In standby mode , press Menu/Enter to enter the Menu B、 In functional menu , press Menu/Enter to confirm selection.
16	Press info to check network status
17	press Pbook to enter the phone book and edit or delete.
18	Press History button to check call history including incoming calls , outgoing calls and missed calls.
19	Exit button A、 when you're dialing , press exit to delete the dialed number and return to and you can dial a new number B、 in functional menu , press EXIT to exit current menu and return to the upper

	menu
20	conference key , when you want to realize conference call , press CONF key and key in the third party number
21	Transfer key
22	Press Hold to hold the call when you are talking
23	Press mute , you can hear the voice from the other end but he can not hear you speaking.
24	Voice volume key A、 press + to turn up the voice volume B、 press - to turn up the voice volume
25	Numeral leys
26	Hand-free button to enter hand-free mode
27	Dial button , when you finish dialing the telephone number , press this button to send out the phone number
28	Del button is used to delete a single number or letter
29	Headset button is used to enter headset answering mode

4th、 Basic functions and operations

1、 Answer the calls

When there is an incoming call, AT610P will remind user with ringing. There are 5 ways to answer the call

A、 Answer by handset

Pick up the handset and talk with the caller. If you want to hang up, just put back the handset.

B、 Hand-free mode

Press the hand-free button in the phone and talk with callers by built-in Micro-phone and Speaker. If you want to hang up, please press the hand-free button again.

C、 Answer by earphone

Keep your earphone connected with the RJ9 earphone jack, when there is an incoming call, press the earphone button on the IP phone and talk with the caller. If you want to hang up, please press the earphone button again.

D、 Handset to hand-free

When you are phoning with the handset and want to phone with hand-free mode, please press the hand-free button and put down the handset.

E、 Hand-free mode to handset

If you are phoning under hand-free mode and want to change to speaker phone, just pick up the handset without press any buttons.

2、 Make Call

A、 Use the handset

Pickup the handset, the LCD will show the current lines. User can input the number with the keyboard and press # to send the number. When you hear the tones of "du~ ~du~ ~" with dialed number showed on the LCD, the called's phone is ringing. If the called answer the call, the phone call is established and the LCD will show the calling time and the called's number.

B、 Answer the phone under hand-free mode

Press the Speaker Phone button, the LCD will show the current lines. User can input the number with the keyboard and press # to send the number. When caller hear the tones of "du~ ~du~ ~" with dialed number showed on the LCD, the called's phone is ringing. If the called answers the call, the phone call is established, and the LCD will show the calling time and the called's number.

C、 Used phone book

- a、 Pick up the phone.
- b、 Press " Pbook" button .
- c、 Press "Menu/Enter" to enter the phone list and use "Vol+" or "Vol-" keys to find the contact person.
- d、 When you find the certain contact person, press" Menu/Enter" to show the details.
- e、 Press "Edit" to edit the number or press" Dial" to call.

3、 Hang up the phone

1) Headset hang up

When use handset mode calling, put back the handset to hang up.

2) Hands free hang up

When use hands free calling, press soft button "speaker phone" to hang up.

3) Earphone Hang up

When use Earphone calling, Press the soft button "headset" to hang up.

4、 Call Transfer

➤ Unattended transfer

If A is using AT510 talking with B , B want to speak to C. A just press XFER and dial C's number

➤ Attended transfer:

Only SIP support attended Transfer. If A is using AT510 talking with B , B want to speak to C. A just press Hold and dial C's number to ask whether he can answer the call from B. C agree , then press Hold to talk with B and press XFER to transfer the call

5、 3-way conference call

Enable Three Way Call

If A is using AT-510 talking with B and B want to make conference call with A and B. A just press Hold and dial C's number . Then press CONF to initiate conference call

6、 Call Hold

User can hold the current call by pressing soft button "Hold". And by pressing soft button "Hold" again,.

7、 Call History.

AT-610P supports 100 missed calls, incoming calls and dialed calls record. When the storage is full, the latest call will update the history. When the phone reboots or be out of power, all the call history will be cleared.

➤ Missed call

- 1) When the LCD screen display the Missed call icon and the status LED is 2s on, 500ms off.
- 2) Press history button, press "Vol+" or "Vol-" to LCD display "Missed".
- 3) Press "Menu/Enter" to display the records of Missed call
- 4) press "Vol+" or "Vol-" browse missed call history.
- 5) Choose the missed call record, press "Redial" button to call this number.

➤ Incoming call

- 1) Press "History" button and press "Vol+" or "Vol-"to LCD display "RECEIVED".
- 2) Press "Menu/Enter" to display received call records.
- 3) press "Vol+" or "Vol-" browse received call records.
- 4) Choose the received call record, press "Redial" button to call this number.
If there is no record, the LCD screen display "List is Empty".

➤ Out coming call

- 1) Press "History" button and press "Vol+" or "Vol-"to LCD display "DIALED".
- 2) Press "Menu/Enter" to display out coming call records.
- 3) press "Vol+" or "Vol-" browse out coming call records.

- 4) Choose the received call record, press “Redial” button to call this number.

If there is no record, the LCD screen display “List is Empty”.

8、 Call pickup

Call pickup is simulated from “Pickup” function processes from IPPBX. When A call B with no reply after ring tones, C could pick up the call from A for B by inputting the prefix and B’s phone No.

C needed to set the dial peer with prefix code as follow

Number	Destination	Port	Mode	Alias	Suffix	Del length
*1*T	0.0.0.0	5060	SIP	rep:pickup	no suffix	3

To refer *1* as the set prefix code, C could get the call from A to B by dialing *1*+B,

1 prefix could be freely set as long as no confliction with other dialing rules.

9、 Join call

“A” could join in the conference call, by input a prefix plus a phone No. which is already in the conference.

A requested to set the prefix code for dial peer as follow

Number	Destination	Port	Mode	Alias	Suffix	Del length
*2*T	0.0.0.0	5060	SIP	rep:joincall	no suffix	3

To refer *2* as the set prefix code, “A” could join in the conference by dial *2* plus the call No. which is already in the conference.

2 prefix could be freely set as long as no confliction with other dialing rules.

10、 Redial/Unredial

In order to being efficiently to contact the busy line, A could use Redial to call B the busy line with setting prefix. When B is free A could get through the call as usual. When B is busy, A could hang the phone with checking B’s situation with every 60S by the set of prefix.

IP Phone of User A would ring and prompt picking up handset if B is available. It would call B automatically once A picking up handset. The call would get through as soon as had set being picked up at B. A could dial the predecessor which set already add number of B to cancel the call before the phone automatic redialing if A is not available suddenly or don’t want to call B

anymore.

Number	Destination	Port	Mode	Alias	Suffix	Del length
*3*T	0.0.0.0	5060	SIP	rep:redial	no suffix	3
*4*T	0.0.0.0	5060	SIP	rep:unredial	no suffix	3

3 is the predecessor. Then A could make the redial function via dialing *3* + number of B.

4 is the predecessor. Then A could make the redial function via dialing *4* + number of B.

User could name any predecessor like *3*/*4* if it is compliant with present dial rule.

11、 vport

Vport makes more flexible calling application. Eg. It could forward a call from Line 1 to one account of Line 2 after configuring forward type and number@line via web interface. The forward could make either from Line 1 to Line 2 or Line 2 to Line 1. But the end user may not aware the configuration being made therefore probably the end user should be advised that it may cost with the forward function. The forwarding could be done via either Line Key to select the line or dialing IP after calling under server. It could be implemented by the following 4 ways:

◆ Point to Point Call Forward

Make the configuration like @ip:port in the column of Forward Number. Then it could make SIP call point to point with this IP and port in system. User could select forward type accordingly.

◆ Point to Point Blind Transfer

Transfer the call via dialing IP directly.

Call Forward, Call Transfer (Blind Transfer/ Attended Transfer) in different Line.

Make the configuration like sip: username@n in the column of Forward Number. Then system would select Line N and make call accordingly.

SIP Line (eg:0/1/2. Or 0.0.0.0/0.0.0.1/0.0.0.2/255.255.255.255 which is compliant with former configuration).

Call Forward, Call Transfer (Blind Transfer/ Attended Transfer) between SIP Line and Point to Pint.

It is compliant for the Call Forward, Call Transfer (Blind Transfer/ Attended Transfer) between SIP Line and Point to Pint.

12、 Click to dial

When User A accesses web interface and calls User B via clicking one link which is direct to B, IP Phone of User A would ring. Then call B automatically once User A picking up handset.

13、 Preload Password

There are 2 models to set the authority of web accessing and command line: Guest model and Admin model. User could view and configure all items in Admin model. While user couldn't change the SIP (1-2) and IAX2 configuration as well as server address and port but only access and view the information. User would enter different model after input different user name and password:

- Guest Model
 - ◆ User Name: guest
 - ◆ Pass word: guest
- Admin Model:
 - ◆ User Name: admin
 - ◆ Pass word: admin

14、 Check the Phone's IP

Press the up or down navigation button to check the phone's IP address

5th、 Web settings

Enter AT-610P IP addresses in the web browser to go to the log on page, and key in the username and password to access AT-610P setting page.

Default username and password is:

Administrator: Username: **admin** password: **admin**

User: Username: **guest** Username: **guest**

1、 Current state

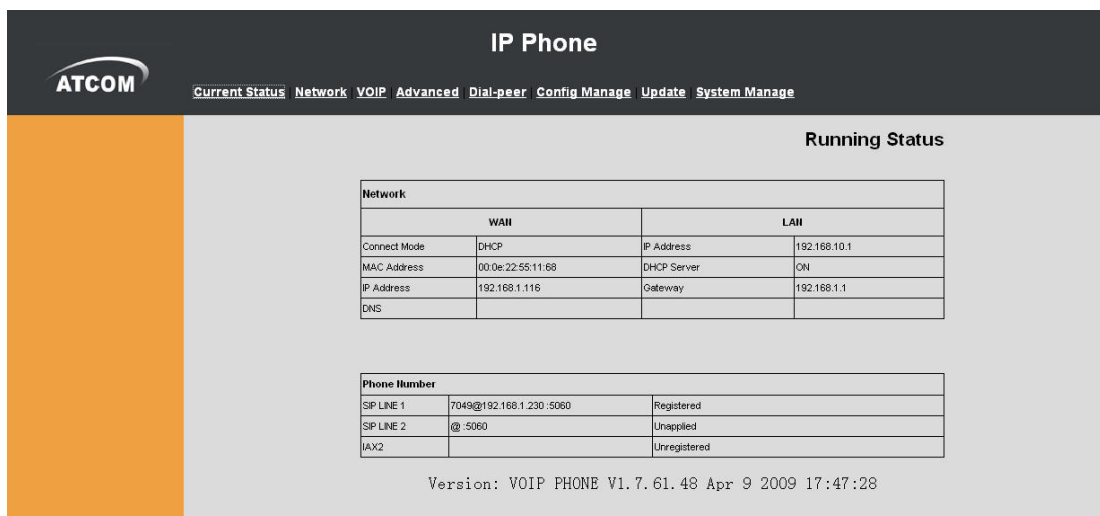

IP Phone

Current Status Network VOIP Advanced Dial-peer Config Manage Update System Manage

Running Status

Network			
WAN		LAN	
Connect Mode	DHCP	IP Address	192.168.10.1
MAC Address	00.0e.22.55.11.68	DHCP Server	ON
IP Address	192.168.1.116	Gateway	192.168.1.1
DNS			

Phone Number		
SIP LINE 1	7049@192.168.1.230:5060	Registered
SIP LINE 2	@-5060	Unapplied
IAX2		Unregistered

Version: VOIP PHONE V1.7.61.48 Apr 9 2009 17:47:28

This page shows the IP phone working status.

The network part shows the connection status of WAN and LAN.

Phone Number part shows the phone number and register status for Line1、Line2 and IAX2

2、 Network

There are 3 ways to connect to the internet DHCP, Static and PPPoE, please choose one according to your own situation

A、 DHCP, the IP phone will get IP address from DHCP server , you do not have to fill in the date of IP address , net mask etc , just choose DHCP and submit . Please refer to the below picture



IP Phone

Current Status Network VOIP Advanced Dial-peer Config Manage Update System Manage

WAN Configuration

WAN Status	
Active IP	192.168.1.48
Current Netmask	255.255.255.0
Current Gateway	192.168.1.254
MAC Address	00:03:04:05:09:28
Get MAC Time	20090625
WAN Setting	
Static <input type="radio"/>	DHCP <input checked="" type="radio"/>
	PPPOE <input type="radio"/>

APPLY

Parameters:

- ✓ Active IP: IP phone's address
- ✓ Current Net mask: network net mask
- ✓ MAC Address: MAC of IP phone

- ✓ Current Gateway: the IP address of the router

B、 If your ISP provide you with the fixed IP address, please choose static and fill in the correct information of IP Address、 Net mask、 Gateway、 Primary DNS etc. If you do not know it please refer to your ISP provider or network management stuff. The reference picture is as below



WAN Status	
Active IP	192.168.1.48
Current Netmask	255.255.255.0
Current Gateway	192.168.1.254
MAC Address	00:03:04:05:09:28
Get MAC Time	20090625
WAN Setting	
Static <input checked="" type="radio"/>	DHCP <input type="radio"/>
PPPOE <input type="radio"/>	
Static IP Address	192.168.1.179
Netmask	255.255.255.0
Gateway	192.168.1.1
DNS Domain	
Primary DNS	202.96.134.133
Alter DNS	202.96.128.68
Auto DNS	<input checked="" type="checkbox"/>

Parameters:

- ✓ Static IP Address: fixed IP address
- ✓ Net mask: LAN net mask
- ✓ Gateway: Gateway IP address
- ✓ DNS Domain: input DNS domain name if it's provided
- ✓ Primary DNS: Primary DNS address
- ✓ Alter DNS: Alternative DNS address

C、 when you use PPPoE to get IP address, please select "PPPoE", and input ADSL account information as below picture:

IP Phone

WAN Configuration

WAN Status	
Active IP	192.168.1.48
Current Netmask	255.255.255.0
Current Gateway	192.168.1.254
MAC Address	00:03:04:05:09:28
Get MAC Time	20090625
WAN Setting	
Static <input type="radio"/>	DHCP <input type="radio"/>
PPPOE <input checked="" type="radio"/>	
PPPOE Server	ANY
Username	user123
Password	*****

Parameters:

PPPoE Server: sever name, if the ITSP have no special requirements, keep the ANY as default

Username: ADSL account user name

Password: ADSL account password

Attention:

- 1) After configuration setting please click "Apply" to effect the change
- 2) If the IP address is changed after effecting the configuration change , the webpage will lose response former address, so you must get to the webpage with new address
- 3) If the LAN IP address is happened to be the same as WAN IP which is allocated from DHCP server. The LAN IP address will be changed automatically by adding 1 at the last digital

3、VoIP

IP Phone

Public SIP Configuration

Basic Setting			
Register status	Registered	Proxy Server Address	<input type="text"/>
Server Address	192.168.1.230	Proxy Server Port	<input type="text"/>
Server Port	5060	Proxy Username	<input type="text"/>
Account Name	7009	Proxy Password	<input type="text"/>
Password	****	Domain Realm	<input type="text"/>
Phone Number	7009	Enable Register	<input checked="" type="checkbox"/>
Display Name	7009		

- ✓ Register Status: SIP server registration status, if succeed display Registered, or else display Unregistered.
- ✓ Server Address: SIP server address , support both IP address and domain name.
- ✓ Server Port: SIP server port , default is 5060.
- ✓ Account Name: SIP account name.
- ✓ Phone Number : SIP account phone number, if leave it as blank , no registration information will be sent out.
- ✓ Display Name: Show the display name that you want to display on the phone of callee. Support number and letter input.
- ✓ Proxy Server Address: Normally the Proxy server is the same as SIP server. If they are different then fill in the correct information that provided by ISP.

Proxy Server Port: Set your SIP server port.

Proxy Username: Input your SIP register account name.

Proxy Password: Input your SIP register password.

Domain Realm: config SIP local domain. If the server does not have special requirements for the local domain of SIP terminal, the local domain can be the same as SIP server domain. The user can also leave it as blank; the system will take SIP server domain as the domain realm.

- ✓ Enable Register: Enable or disable registration

Advanced SIP setting

Advanced Set

Advanced SIP Setting			
Register Expire Time	<input type="text" value="60"/> seconds	Forward Type	Off <input type="button" value="v"/>
Auto Detect Server Interval	<input type="text" value="60"/> seconds	Forward Phone Number	<input type="text"/>
User Agent	<input type="text" value="Voip Phone 1.0"/>	Server Type	common <input type="button" value="v"/>
Signal Key	<input type="text"/>	DTMF Mode	DTMF_RFC2833 <input type="button" value="v"/>
Media Key	<input type="text"/>	RFC Protocol Edition	RFC3261 <input type="button" value="v"/>
Local Port	<input type="text" value="5060"/>	Transport Protocol	UDP <input type="button" value="v"/>
Hot Line Number	<input type="text"/>	Subscribe Expire Time	<input type="text" value="300"/> seconds
Enable Conference Num	<input type="checkbox"/>	Conference Number	<input type="text"/>
Enable Keep Authentication	<input type="checkbox"/>	Signal Encode	<input type="checkbox"/>
Auto Detect Server	<input type="checkbox"/>	Rtp Encode	<input type="checkbox"/>
Enable Via rport	<input checked="" type="checkbox"/>	Enable Session Timer	<input type="checkbox"/>
Enable PRACK	<input type="checkbox"/>	Answer With Single Codec	<input type="checkbox"/>
Long Contact	<input type="checkbox"/>	Auto TCP	<input type="checkbox"/>
Click To Talk	<input type="checkbox"/>	Enable URI Convert	<input checked="" type="checkbox"/>
Ban Anonymous Call	<input type="checkbox"/>	Enable Displayname Quote	<input type="checkbox"/>
Dial Without Register	<input type="checkbox"/>	Enable GRUU	<input type="checkbox"/>
Enable Strict Proxy	<input type="checkbox"/>	Enable Subscribe	<input type="checkbox"/>

- ✓ Register Expire Time: register expire time, default is 600 seconds. AT-610P will auto configure this expire time to the server recommended setting if it is different from the SIP server.

- ✓ Auto Detect Server Interval: Set examining interval of the server, default is 60 seconds
- ✓ User Agent: Set the user agent if have, the default is VoIP Phone 1.0
- ✓ Signal Key: Signal encryption Key:
- ✓ Media Key: voice stream encryption Key
- ✓ Local Port: Local SIP signal port, default as 5060
- ✓ Hotline Number: Set hot line number of each line
- ✓ Enable Conference Num: conference ID
- ✓ Auto Detect Server: Enable/Disable keeps NAT of SIP alive. If some server refuse to register with too short interval time, and has no packets sending to device in private network to keep NAT alive, user could set this function ON. It need set the keep alive interval time less than the NAT server's.
- ✓ Enable Keep Authentication: Enable/Disable Keep Authentication System will take the last authentication field which is passed the authentication by server to the request packet. It will decrease the server's repeat authorization work, if it is enable.
- ✓ Enable Via rport: Enable/Disable system to support RFC3581. Via rport is special way to realize SIP NAT.
- ✓ Enable PRACK: Enable or disable SIP PRACK function, suggest use the default config.
- ✓ Long Contact: Set more parameters in contact field.
- ✓ Click to Talk: Set click to Talk (need practical software support).
- ✓ Ban Anonymous Call: Set to ban Anonymous Call.
- ✓ Dial Without Register: Set call out by proxy without registration.
- ✓ Enable Strict Proxy: Support the special SIP server-when phone receives the packets sent from server, phone will use the source IP address, not the address in via field.
- ✓ Forward Type: Select call forward mode, the default is Off .
- ✓ Off: Close down calling forward.
- ✓ Busy: If the phone is busy, incoming calls will be forwarded to the appointed phone.
- ✓ No answer: If there is no answer, incoming calls will be forwarded to the appointed phone.
- ✓ Always: Incoming calls will be forwarded to the appoint phone directly.
- ✓ The phone will prompt the incoming while doing forward.
- ✓ Forward Phone Number: Appoint your forward phone number.
- ✓ Server Type: Select the special type of server which is encrypted, or has some unique requirements or call flows.
- ✓ DTMF Mode: Select DTMF sending mode, there are three modes:
 - DTMF_RELAY
 - DTMF_RFC2833
 - DTMF_SIP_INFO.
- ✓ Different VoIP Service providers may provide different modes.
- ✓ RFC Protocol Edition: Select SIP protocol version to adapt for the SIP server

which uses the same version as you select. For example, if the server is CISCO5300, you need to change to RFC2543; else phone may not cancel call normally. System uses RFC3261 as default.

- ✓ Transport Protocol: Set transport protocols, TCP or UDP.
- ✓ Subscribe Expire Time: Overtime of resending subscribe packet. Suggest using the default config.
- ✓ Conference Number: config certain Conference call number.
- ✓ Signal Encode: enable signal encryption.
- ✓ Rtp Encode: enable voice data encryption.
- ✓ Enable Session Timer: enable rfc4028 to refresh the SIP sessions.
- ✓ Answer With Single Codec: only answer the call with a certain Codec.
- ✓ Auto TCP: enable TCP transmission protocol when the length of message exceed 1300 byte.
- ✓ Enable URI Convert: convert # into %23 when sending URI.
- ✓ Enable Display name Quote: Set to make quotation mark to display name as the phone sends out signal, in order to be compatible with server. Enable GRUU: Set to support GRUU.
- ✓ Enable Subscribe: Enable Subscribe: Overtime of resending subscribe packet. Suggest using the default config.

4、Advance

4.1. SIP



Basic Setting			
Register status	Registered	Proxy Server Address	<input type="text"/>
Server Address	192.168.1.230	Proxy Server Port	<input type="text"/>
Server Port	5060	Proxy Username	<input type="text"/>
Account Name	7009	Proxy Password	<input type="text"/>
Password	••••	Domain Realm	<input type="text"/>
Phone Number	7009	Enable Register	<input checked="" type="checkbox"/>
Display Name	7009		

- ✓ Register Status: SIP server registration status, if succeed display Registered, or else display Unregistered.
- ✓ Server Address: SIP server address , support both IP address and domain name.
- ✓ Server Port: SIP server port , default is 5060.
- ✓ Account Name: SIP account name.

- ✓ Phone Number: SIP account phone number, if leave it as blank, no registration information will be sent out.
- ✓ Display Name: Show the display name that you want to display on the phone of callee. Support number and letter input.
- ✓ Proxy Server Address: Normally the Proxy server is the same as SIP server. If they are different then fill in the correct information that provided by ISP.

Proxy Server Port: Set your SIP server port.

Proxy Username: Input your SIP register account name.

Proxy Password: Input your SIP register password.

Domain Realm: config SIP local domain. If the server does not have special requirements for the local domain of SIP terminal, the local domain can be the same as SIP server domain. The user can also leave it as blank , the system will take SIP server domain as the domain realm.

- ✓ Enable Register: Enable or disable registration

✓ **Advanced SIP setting**

Advanced SIP Setting			
Register Expire Time	<input type="text" value="60"/> seconds	Forward Type	Off <input type="button" value="v"/>
Auto Detect Server Interval	<input type="text" value="60"/> seconds	Forward Phone Number	<input type="text"/>
User Agent	<input type="text" value="Voip Phone 1.0"/>	Server Type	common <input type="button" value="v"/>
Signal Key	<input type="text"/>	DTMF Mode	DTMF_RFC2833 <input type="button" value="v"/>
Media Key	<input type="text"/>	RFC Protocol Edition	RFC3261 <input type="button" value="v"/>
Local Port	<input type="text" value="5060"/>	Transport Protocol	UDP <input type="button" value="v"/>
Hotline Number	<input type="text"/>	Subscribe Expire Time	<input type="text" value="300"/> seconds
Conference Number	<input type="text"/>	Enable Conference Num	<input type="checkbox"/>
Enable Keep Authentication	<input type="checkbox"/>	Signal Encode	<input type="checkbox"/>
Auto Detect Server	<input type="checkbox"/>	Rtp Encode	<input type="checkbox"/>
Enable Via rport	<input checked="" type="checkbox"/>	Enable Session Timer	<input type="checkbox"/>
Enable PRACK	<input type="checkbox"/>	Answer With Single Codec	<input type="checkbox"/>
Long Contact	<input type="checkbox"/>	Auto TCP	<input type="checkbox"/>
Click To Talk	<input type="checkbox"/>	Enable URI Convert	<input checked="" type="checkbox"/>
Ban Anonymous Call	<input type="checkbox"/>	Enable Displayname Quote	<input type="checkbox"/>
Dial Without Register	<input type="checkbox"/>	Enable GRUU	<input type="checkbox"/>
Enable Strict Proxy	<input type="checkbox"/>	Enable Subscribe	<input type="checkbox"/>
<input type="button" value="APPLY"/>			

- ✓ Register Expire Time: register expire time, default is 600 seconds. AT-610P will auto configure this expire time to the server recommended setting if it is different from the SIP server.
- ✓ Auto Detect Server Interval: Set examining interval of the server, default is 60 seconds.

User Agent: Set the user agent if have, the default is VoIP Phone 1.0.

Signal Key: Signal encryption Key:

- ✓ Media Key: voice stream encryption Key.
- ✓ Local Port: Local SIP signal port, default as 5060.

Enable Conference Num: conference ID

- ✓ Auto Detect Server: Enable/Disable keeps NAT of SIP alive. If some server refuse to register with too short interval time, and has no packets sending to device in private network to keep NAT alive, user could set this function ON. It need set the keep alive interval time less than the NAT server's.

Enable Keep Authentication: Enable/Disable Keep Authentication System will take the last authentication field which is passed the authentication by server to the request packet. It will decrease the server's repeat authorization work, if it is enable.

Enable Via rport: Enable/Disable system to support RFC3581. Via rport is special way to realize SIP NAT.

Enable PRACK: Enable or disable SIP PRACK function, suggest use the default config.

Long Contact: Set more parameters in contact field;

Click To Talk: Set click to Talk (need practical software support).

Ban Anonymous Call: Set to ban Anonymous Call.

Dial without Register: Set call out by proxy without registration.

Enable Strict Proxy: Support the special SIP server-when phone receives the packets sent from server, phone will use the source IP address, not the address in via field.

Forward Type: Select call forward mode, the default is off.

- Off: Close down calling forward.
- Busy: If the phone is busy, incoming calls will be forwarded to the appointed phone.
- No answer: If there is no answer, incoming calls will be forwarded to the appointed phone.
- Always: Incoming calls will be forwarded to the appoint phone directly. The phone will prompt the incoming while doing forward.

Forward Phone Number: Appoint your forward phone number.

Server Type: Select the special type of server which is encrypted, or has some unique requirements or call flows.

DTMF Mode: Select DTMF sending mode, there are three modes:

- DTMF_RELAY
- DTMF_RFC2833
- DTMF_SIP_INFO。

Different VoIP Service providers may provide different modes.

RFC Protocol Edition: Select SIP protocol version to adapt for the SIP server which uses the same version as you select. For example, if the server is CISCO5300, you need to change to RFC2543; else phone may not cancel call normally. System uses RFC3261 as default.

Transport Protocol: Set transport protocols, TCP or UDP;

Subscribe Expire Time: Overtime of resending subscribe packet. Suggest to use

the default config.

- ✓ Conference Number: config certain Conference call number
- ✓ Signal Encode: enable signal encryption
- ✓ Rtp Encode: enable voice data encryption
- ✓ Enable Session Timer: enable rfc4028 to refresh the SIP sessions
- ✓ Answer With Single Codec: only answer the call with a certain Codec
- ✓ Auto TCP: enable TCP transmission protocol when the length of message exceed 1300 byte
- ✓ Enable URI Convert: convert # into %23 when sending URI

Enable Display name Quote: Set to make quotation mark to display name as the phone sends out signal, in order to be compatible with server. Enable GRUU: Set to support GRUU;

Enable Subscribe: Enable Subscribe: Overtime of resending subscribe packet. Suggest using the default config.

4.2. Digital Map



The screenshot shows the ATCOM IP Phone configuration interface. The top navigation bar includes 'Current Status', 'Network', 'VOIP', 'Advanced', 'Dial-peer', 'Config Manage', 'Update', and 'System Manage'. The 'Digital Map' section is active, showing a sidebar with 'SIP', 'Digital Map', 'STUN', 'Call Service', and 'Audio Settings'. The main content area is titled 'Digital Map' and contains two sections: 'Digital Map Set' and 'Digital Rule table'.

Digital Map Set

<input checked="" type="checkbox"/>	End with "#"	
<input type="checkbox"/>	Fixed Length	11
<input checked="" type="checkbox"/>	Time out	5 (3--30)

Digital Rule table

Rules:
*[1-8]xxx
*9xxxxxxx
911
88T4
6611x.T4

Digit map is a set of rules to determine when the user has finished dialing.

AT610P support below digital map:

- ✓ End With "#": Use # as the end of dialing.
- ✓ Fixed Length: The call will be sent out automatically when the length of the number you dial reaches the fixed one. For example if you set number of 11 here, when you dial 11 digits the call will be sent out immediately.
- ✓ Timeout: Specify the timeout of the last dial digit. The call will be sent after timeout.
- ✓ Prefix: User define digital map:
- ✓ [] represents the range of digit, can be a range such as [1-4], or use comma such as [1,3,5], or use a list such as [234]

- ✓ x represents any one digit between 0~9
- ✓ Tn represents the last digit timeout. n represents the time from 0~9 second, it is necessary. Tn must be the last two digit in the entry. If Tn is not included in the entry, we use T0 as default, it means system will sent the number immediately if the number matches the entry.
- ✓ Example:
 - [1-8]xxx All number from 1000 to 89999 will be sent immediately.
 - 9xxxxxxx 8 digits numbers begin with 9 will be sent immediately.
 - 911 Number 911 will be sent will be immediately
 - 88xT4 3 digits numbers begin with 88with be sent after four seconds.
 - 6611x.T4 holds four seconds send out if the number begins 6611 and five digits.
- ✓ Attention: The above configuration can exist at the same time. For example you enable # as the signal of sending the call while set fixed length of 11. Either you press # before the number reach 11 or dial 11 digital can send out the call

4.3. Stun

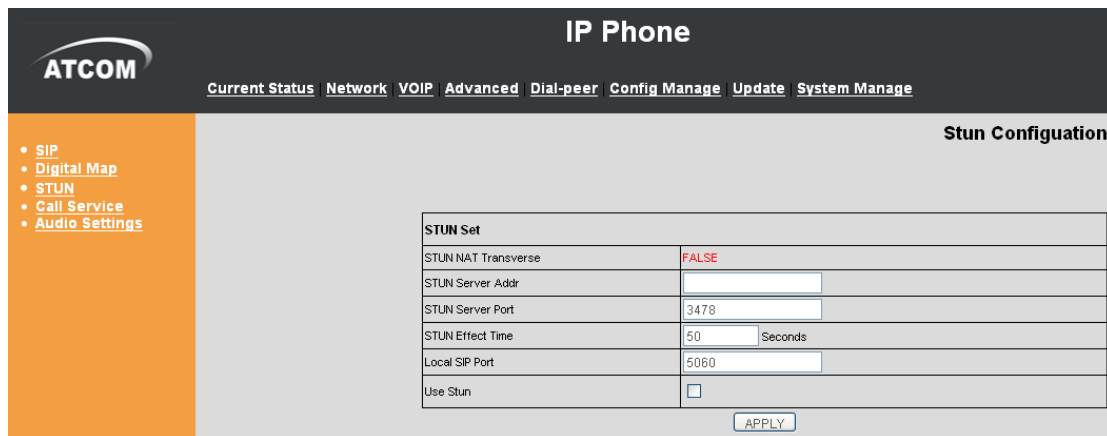

- ✓ STUN NAT Transverse: STUN NAT Transverse status true or false
- ✓ STUN Server Addr: configure stun server address;
- ✓ STUN Server Port: configure stun server port default 3478
- ✓ STUN Effect Time: stun detect NAT type interval time .If NAT found a link inactive for a certain time , it will close the link so you need to send a packet within a interval tome to keep the link alive
- ✓ Local SIP Port: config local SIP port , default as 5060Use Stun : enable/disable SIP STUN

Attention:

SIP STUN is used for NAT transverse. When you config STUN server's

address and port (default 3478) and enable it, then you can use the normal SIP server to make the IP phone transverse NAT.

4.4. Call Service



Call Service Setting			
No Answer Time	20 (seconds)	P2P IP Prefix	.
No Disturb	<input type="checkbox"/>	Ban Outgoing	<input type="checkbox"/>
Enable Call Transfer	<input checked="" type="checkbox"/>	Enable Call Waiting	<input checked="" type="checkbox"/>
Auto Answer	<input type="checkbox"/>	Accept Any Call	<input checked="" type="checkbox"/>
Enable Three Way Call	<input checked="" type="checkbox"/>		

Apply

Black List

<input type="text"/>	Add	<input type="text"/>	Delete
----------------------	-----	----------------------	--------

Limit List

<input type="text"/>	Add	<input type="text"/>	Delete
----------------------	-----	----------------------	--------

- ✓ Hotline: configure hotline number. AT-610P immediately dials this number after hook-off if it is set and the user can not dial any other number.
- ✓ No Answer Time: no answer call forward time setting.
- ✓ No Disturb: DND, do not disturb, when there is an incoming call , the caller will get the message that this line is not available , but you it has no affection when you make outgoing call.
- ✓ Ban Outgoing: Enable this to ban outgoing calls.
- ✓ Enable Call Transfer: Enable Call Transfer by selecting it.
- Enable Call Waiting: Enable Call Waiting by selecting it.
- ✓ Enable Three Way Call: 3 way conference call.

Accept Any Call: If select it, the phone will accept the call even if the called number is not belong to the phone.

Auto Answer: If select it, the phone will auto answer when there is an incoming call.

P2P IP Prefix: Set Prefix in peer to peer IP call. For example: what you want to dial is 192.168.1.119, If you define P2P IP Prefix as 192.168.1., you dial only #119 to reach 192.168.1.119. Default is ".". If there is no "." Set, it means to disable dialing IP.

Voicemail Number: Set the voicemail number for each line.

Black List: Set Add/Delete Black list , incoming call in these phone numbers will be refused.

It support below rules,

- You add a certain number in it , when this number call you , it will be refused.
- Use "x" to represent any number. For example , 4xx means any incoming

call with 3 digital and the first digital is 4 , will be refused.

➤ DOT (.) means matching any arbitrary number digit. for example, any number with prefix 6 will be forbidden to dialed out. Any digital call with a certain head number, For example **6.** means any incoming number with the 6 as the first number will be refused.

➤ if user wants to allow a number or a series of number incoming, he may add the number(s) to the list as the white list rule. the configuration rule is –number, for the settings as below.

Black List			
-7049			
<input type="text"/>	<input type="button" value="Add"/>	-7049 <input type="button" value="v"/>	<input type="button" value="Delete"/>

-7049 means any incoming number is forbidden except 7049

Note: End with DOT (.) when set up the white list

Limit List:

Set Add/Delete Limit List. Please input the prefix of those phone numbers which you forbid the phone to dial out. For example, if you want to forbid those phones of 001 as prefix to be dialed out, you need input 001 in the blank of limit list, and then you cannot dial out any phone number whose prefix is 001. x and . are wildcard. x means matching any single digit. for example, 4xxx expresses any number with prefix 4 which length is 4 will be forbidden to dialed out . Means matching any arbitrary number digit. For example, 6. expresses any number with prefix 6 will be forbidden to dialed out.

4.5. Audio Settings



IP Phone

Current Status
Network
VOIP
Advanced
Dial-peer
Config Manage
Update
System Manage

Audio Settings

- SIP
- Digital Map
- STUN
- Call Service
- **Audio Settings**

DSP Configuration			
First Codec	<input type="text" value="g711Ulaw64k"/>	Second Codec	<input type="text" value="g711Alaw64k"/>
Third Codec	<input type="text" value="g729"/>	Fourth Codec	<input type="text" value="g723"/>
Fifth Codec	<input type="text" value="g711Alaw64k"/>	Handdown Time	<input type="text" value="200"/> ms
Input Volume	<input type="text" value="3"/> (1-9)	Output Volume	<input type="text" value="9"/> (1-9)
Handfree Volume	<input type="text" value="9"/> (1-9)	HeadSet Volume	<input type="text" value="5"/> (1-9)
G729 Payload Length	<input type="text" value="20ms"/>	Signal Standard	<input type="text" value="China"/>
G722 Timestamps	<input type="text" value="160/20ms"/>	G723 Bit Rate	<input type="text" value="8.3kb/s"/>
Default Ring Type	<input type="text" value="Type 1"/>	VAD	<input type="checkbox"/>
Ring Volume	<input type="text" value="5"/> (1-9)		

First Codec: The first preferential DSP codec: G.711A/u、G.722、G.723、G.729

Second Codec: The second preferential DSP codec: G.711A/u、G.722、G.723、G.729

Third Codec: The third preferential DSP codec: G.711A/u、G.722、G.723、G.729

Forth Codec: The Forth preferential DSP codec: G.711A/u、G.722、G.723、G.729

ATCOM TECHNOLOGY CO., LIMITED

Fifth Codec: The fifth preferential DSP codec: G.711A/u、G.722、G.723、G.729
 Input Volume: Specify Input (MIC) Volume grade;
 Output Volume: Specify Output (receiver) Volume grade.
 Hands free Volume: Specify Hands free Volume grade
 Ring Volume: Specify Ring Volume grade
 G729 Payload Length: Set G729 Payload Length
 Signal Standard: Select Signal Standard.
 G722 Timestamps: 160/20ms or 320/20ms is available;
 G723 Bit Rate: 5.3kb/s or 6.3kb/s is available;
 Default Ring Type: Select signal standard;
 VAD: Select it or not to enable or disable VAD. If enable VAD, G729 Payload length could not be set over 20ms.

5、Dial Peer

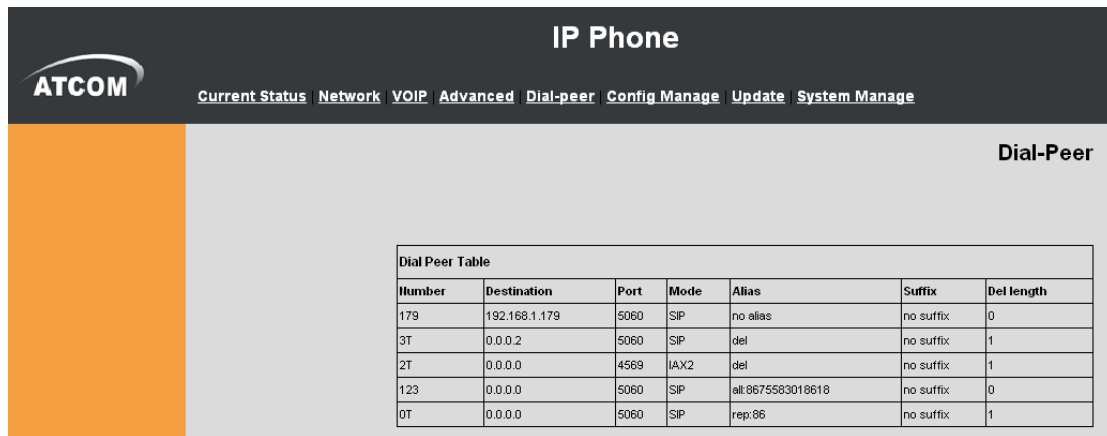

Number	Destination	Port	Mode	Alias	Suffix	Del length
179	192.168.1.179	5060	SIP	no alias	no suffix	0
3T	0.0.0.2	5060	SIP	del	no suffix	1
2T	0.0.0.0	4569	IAX2	del	no suffix	1
123	0.0.0.0	5060	SIP	all:8675583018618	no suffix	0
0T	0.0.0.0	5060	SIP	rep:86	no suffix	1

This functionality offers you more flexible dial rule, you can refer to the following content to know how to use this dial rule. When you want to dial an IP address, the entry of IP addresses is very cumbersome, but by this functionality, you can set number 179 to replace 192.168.1.179 here.

When you want to dial a long distance call to China, you need dial an country code 86 before local phone number, but you can also dial number 0 instead of 86 after we make a setting according to this dial rule. For example, you want to dial 8675583018619, but you need dial only 075583018619 to realize your long distance call after you make this setting.

AT610P provide flexible dial rule, with different dial-rule configure, user can easily implement the following function:

- Replace, delete or add prefix of the dial number.
- Make direct IP to IP call
- Place the call to different servers according the prefix.

You can click "Add" to add a new dial rule. Below is the detail setting of the dial-rule:

Phone Number: The Number suit for this dial rule, can be set as full match or prefix match. Full match means that if the number user dialed is completely the same as this number, the call will use this dial-rule. Prefix match means that if prefix of the number that the user dials is the same as the prefix, the call will use this dial-rule, to distinguish from the full match case, you need to add "T" after the prefix number in the phone number setting.

Call Mode: support SIP..

Destination (optional): call destination, can be IP or domain. Default is 0.0.0.0; in this case the call will be routed to the Public SIP server. If you set the destination to 255.255.255.255, then the call will be routed to the private SIP server. Also you can key other address here to make direct IP calls

Port (optional): Configure the port of the destination, default is 5060 in SIP

Alias (optional): Set up the Alias. We support four Alias as below. Alias need to co-work with the *Del Length*:

- add:xxx, add prefix to the phone number, can set to reduce the dial length.
- all: xxx, replace the phone number with the xxx, can use as speed dial function.
- Del, delete the first N numbers. N is set in the *Del Length*.
- rep:xxx, replace the first N numbers. N is set in the *Del Length*. For Example:

Use wants to place a call 8610-62281493, then you can set the *phone number* in the dial rule as 010T, and set the *Alias* as rep:8610, and set the *Del Length* to 3. Then all calls begin with 010 will be changed to 8610 xxxxxxxx.

Suffix (optional): Configure suffix, show no suffix if not set

Instance description as picture:

179 rule: when you dial 179, the call with send to 192.168.1.179, suit for LAN application without set up a sip server.

3T rule: If the call starts with 3, the first 3 will be deleted, and the rest number with be sent to public SIP2 server.

2T rule: if the call starts with 2, the first 2 will be deleted, and the rest number with be sent to IAX2 Server.

123 rule: Dial 123 and will send 8675583018049 to your server. Used as speed dial function.

0T rule: If the calls are begin with 0, the first 0 will be replacing by 86. Mean that if you dial 075583018049 and AT610P will send 8675583018049 to your server.

Add Dial Peer	
Phone Number	<input type="text"/>
Destination (optional)	<input type="text"/>
Port(optional)	<input type="text"/>
Alias(optional)	<input type="text"/>
Call Mode	SIP <input type="button" value="v"/>
Suffix(optional)	<input type="text"/>
Delete Length (optional)	<input type="text"/>
<input type="button" value="Submit"/>	

Dial Peer Option	
179 <input type="button" value="v"/>	<input type="button" value="Delete"/> <input type="button" value="Modify"/>

Phone number: There are two types of matching conditions: one is full matching, the other is prefix matching. In the full matching, you need input your desired phone number in this blank, and then you need dial the phone number to realize calling to what the phone number is mapped. In the prefix matching, you need input your desired prefix number and T; then dial the prefix and a phone number to realize calling to what your prefix number is mapped. The prefix number supports at most 30 digits.

Destination: Set Destination address. This is optional config item. If you want to set peer to peer call, please input destination IP address or domain name. If you want to use this dial rule in SIP2 line, you need input 0.0.0.2 in it. If not config, default sip1 as 0.0.0.0.

Port: Set the Signal port, the default is 5060 for SIP;

Alias: Set alias. This is optional config item. If you don't set Alias, it will show no alias.

Note: There are four types of aliases.

- 1) add: xxx, it means that you need dial xxx in front of phone number, which will reduce dialing number length.
- 2) all: xxx, it means that xxx will replace some phone number.
- 3) del: It means that phone will delete the number with length appointed.
- 4) Rep: It means that phone will replace the number with length and number appointed. You can refer to the following examples of different alias application to know more how to use different aliases and this dial rule.

Call Mode: Select difference signal protocol, SIP or IAX2;

Suffix: Set suffix, this is optional config item. It will show no suffix if you don't set it;

Delete Length: Set delete length. This is optional config item. For example: if the delete length is 3, the phone will delete the first 3 digits then send out the rest digits. You can refer to examples of different alias application to know how to set delete length;

6、 Config Manage



Save Config: you can save all changes of configurations. Click the Save button, all changes of configuration will be saved, and be effective immediately.

Backup Config: Right clicks on “Right click here...” and select “Save Target As...” then you will save the config file in .txt format

Clear Config: user can restore factory default configuration and reboot the phone. If you login as Admin, the phone will reset all configurations and restore factory default; if you login as Guest, the phone will reset all configurations except for VoIP accounts (SIP1、 SIP2 and IAX2) and version number.

7、 Update

7.1. Web Update



Click the browse button, find out the config file saved before or provided by manufacturer, download it to the phone directly, press “Update” to save. You can

also update downloaded update file, logo picture, ring, mmiset file by web.

7.2. FTP/TFTP Update



- ✓ Server: FTP/TFTP server address. It can be the format of IP address such as 192.168.1.1 or domain such as ftp.domain.com Meanwhile , it support sub directory such as 192.168.1.1/ftp/config/ or ftp.domain.com/ftp/config
- ✓ Username: FTP user name (TFTP no need)
- ✓ Password: FTP password (TFTP no need)
- ✓ File name: the firmware or configuration file name that IP phone will search for in the server , if leave it as blank the IP phone will search the file with the name of its MAC such as 000102030405

Notice: Users can revise the exported config file by themselves and import the config file with only modules, for example if there is the SIP setting page in the config file , the IP phone will only change SIP setting after import this file and leave other setting as not changed.

- ✓ Type: upgrading type
 - Application update: update firmware.
 - Config file export: export the current configuration to a FTP/TFTP server
 - Config file import: import configuration file from a FTP/TFTP server
 - Protocol: choose server type FTP or TFTP

7.3. Auto Provisioning



Auto Update Setting	
Current Version	2.0002
Server Address	<input type="text" value="0.0.0.0"/>
Username	<input type="text" value="user"/>
Password	<input type="password" value="****"/>
Config File Name	<input type="text"/>
Config Encrypt Key	<input type="text"/>
Protocol Type	FTP <input type="button" value="v"/>
Update Interval Time	<input type="text" value="1"/> Hour
Update Mode	Disable <input type="button" value="v"/>

- ✓ Current Version: the system will display the current version number need to modify the version id need to more than this number on the config file before auto provision update.
- ✓ Server Address: FTP/TFTP server address
- ✓ Username: FTP server user name
- ✓ Password: FTP server password
- ✓ Config File Name: The name of configuration file. Normally users leave it as blank the IP phone search for the file with the name same as its MAC in the server
- ✓ Config Encrypt Key: The encrypt key of confirmation file
- ✓ Protocol Type: The protocol type that used for upgrading. FTP TFTP and Http
- ✓ Update Interval Time: The interval time that the terminals search for new configuration file , counted in hour
- ✓ Update Mode: auto provision mode;
 - A、Disable: not auto update,
 - B、Update after reboot: auto update after reboot,
 - C、Update at time interval: auto update after a certain time

8、 System Manage

8.1. Account Manage



IP Phone

ATCOM

Current Status Network VOIP Advanced Dial-peer Config Manage Update System Manage

Account Manage

- Account Manage
- Phone Book
- Syslog Config
- Time Set
- Call Log
- Logout
- Reboot

Set Keyboard Password

Keypad password

Set

User Set

User Name	User Level
admin	Root
guest	General

Add User

User name

User level

Password

Confirm

Submit

Account Option

admin

Users can add new account or delete and change existing account

Keyboard Password: config password that you use keyboard to access the menu , must be in number.

- ✓ User Name: set new account name
- ✓ User Level: set new account level; root can read and change setting, general can only read
- ✓ Password: config password for new account
- ✓ Confirm: double confirm password

If you want to make change on existing account , select the account and click **【Modify】** or **【Delete】** . General account can only modify or delete general account

8.2. Phone Book

- ✓ Phonebook Table: shows phonebook detailed information
- ✓ Add Phone Book: add a new record in phonebook
- ✓ Name: nick name of a number , when the call of this number comes in the LCD will show the name
- ✓ Number: phone number
- ✓ Ring Type: ring tone

If you want to make change on existing account , select the account and click **【Modify】** or **【Delete】** . General account can only modify or delete general account

Notice: Maximum records of phone book is 500pcs

8.3. Syslog Config

Syslog is a protocol which is used to record the log messages with client/server mechanism.

Syslog server receives the messages from clients, and classifies them based on priority and type. Then these messages will be written into log by some rules

which administrator can configure. This is a better way for log management. 8 levels in debug information: Level 0---emergency: This is highest default debug info level. Your system can not work.

Level 1---alert: Your system has deadly problem.

Level 2---critical: Your system has serious problem.

Level 3---error: The error will affect your system working.

Level 4---warning: There are some potential dangers. But your system can work.

Level 5---notice: Your system works well in special condition, but you need to check its working environment and parameter.

Level 6---info: the daily debugging info.

Level 7---debug: the lowest debug info. Professional debugging info from R&D person.

At present, the lowest level of debug information send to Syslog is info, debug level only can be displayed on telnet.

The items describe:

- ✓ Server IP: Syslog server IP address
- ✓ Server Port: Syslog server port
- ✓ MGR Log Level: config MGR log level
- ✓ SIP Log Level: config SIPllog level
- ✓ IAX2 Log Level: config IAX2log level
- ✓ Enable Syslog: Enable/Disable Syslog

8.4. Time Set

Time setting

SNTP Time Set	
Server	<input type="text" value="209.81.9.7"/>
Timezone	<input type="text" value="(GMT+08:00)Beijing,Chongqing,Hong Kong,Urumqi"/> ▼
Timeout	<input type="text" value="60"/> (seconds)
12 Hours Systems	<input type="checkbox"/>
Sntp	<input checked="" type="checkbox"/>

Daylight Timeset		
Enable daylight	<input type="checkbox"/>	
	Start Date	End Date
Months	<input type="text" value="March"/> ▼	<input type="text" value="October"/> ▼
week	<input type="text" value="5"/> ▼	<input type="text" value="5"/> ▼
Day	<input type="text" value="Sunday"/> ▼	<input type="text" value="Sunday"/> ▼
Hour	<input type="text" value="2"/>	<input type="text" value="2"/>
Minute	<input type="text" value="0"/>	<input type="text" value="0"/>

Manual Timeset	
Year	<input type="text"/>
Months	<input type="text"/>
Day	<input type="text"/>
Hour	<input type="text"/>
Minute	<input type="text"/>

- ✓ Server: type the IP address of time server
- ✓ Timezone: select correct time zone in list box
- ✓ Timeout: longest response time for SNTP
- ✓ Daylight Timeset: daylight setting through manual
- ✓ Manual Timeset: Time setting through manual
- ✓ Enable Daylight: Daylight saving time

8.5. Call Log

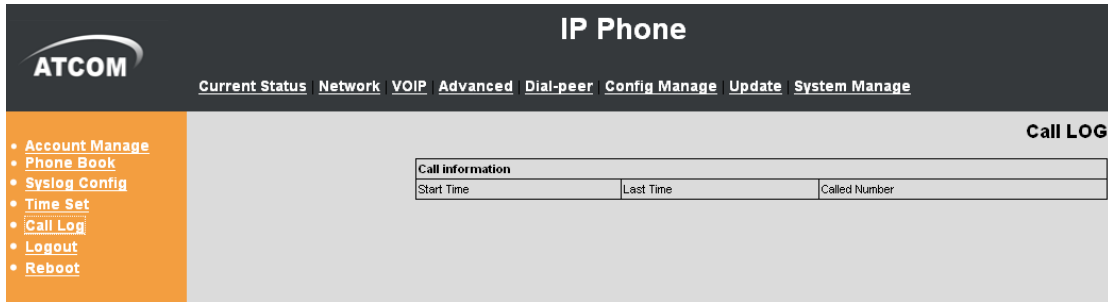

Start Time: Display starts time of the outgoing record.

Last Time: Display conversation time of the outgoing record.

Called Number: Display the account/protocol/line of the outgoing record.

Notice:

It will cover existing automatically if the call log table has the new record.

8.6. Logout

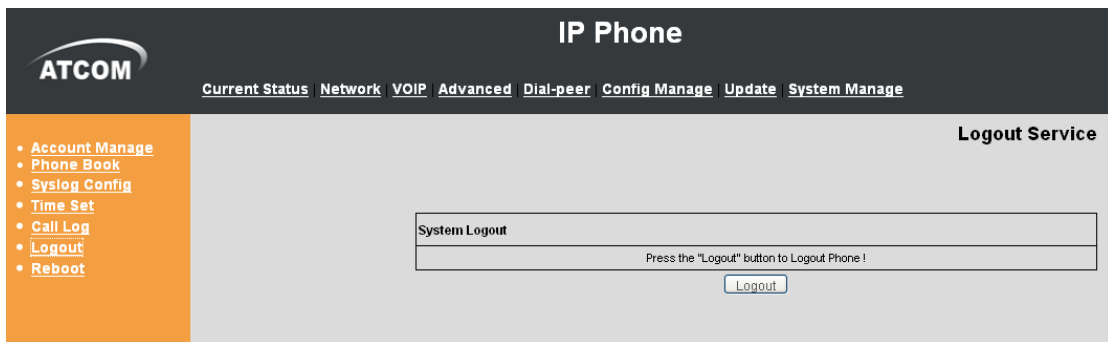

Log out the configuration mode. If you want to re-configuration the phone, need to input the user and password to login again.

8.7. Reboot



Reboot IP phone, some setting needs to reboot to make it works. Please always save config before reboot, otherwise the setting will return to previous setting.